

DeckHand *Portable Scale*



Shown with optional ramp.



(SEE CHART ON BACK OF PAGE FOR PART NUMBERS)

Designed for easy one-person operation, the DeckHand portable floor scale features two large rubber wheels for easy movement on rough floors. Unlike portable scales that rest on four wheels, the DeckHand's wheels only touch the floor when the unit is tilted back for movement. This means the weighing platform remains stable even on uneven floors.

Available in mild or stainless steel, these rugged scales stand up to tough conditions. Two opposed off-center load cells provide superior accuracy without the need for leveling feet. IQ plus® series indicators can be easily column-mounted with slight modifications. A mounting bracket for models IQ plus 310A, IQ plus 390-DC, IQ plus 510, IQ plus 590-DC, IQ plus 710, and IQ plus 800 indicators come standard on the column assembly.

Standard Features

- Mild or stainless steel wheeled frame, base, and mast
- Treaded top plate
- 500 lb, 1000 lb, 2000 lb capacity
- Standard indicator mount with integral handles for the IQ plus® 310A, IQ plus® 390-DC, IQ plus® 510, IQ plus® 590-DC, IQ plus® 710, and IQ plus® 800 indicators. Mild or stainless steel available
- Large rubber wheels simplify movement on uneven floors
- One-person portability
- RL1260 aluminum load cells

Options/Accessories

- 41292* Clam shell for 1260 load cell, stainless steel
- 43376 Ramp assembly, 500/1000 lb, mild steel, 25" x 27"
- 43377 Ramp assembly, 500/1000 lb, stainless steel, 25" x 27"
- 43378 Ramp assembly, 2000 lb, mild steel, 25" x 27"
- 43379 Ramp assembly, 2000 lb, stainless steel, 25" x 27"
- 43978 Additional DeckHand operating manual

* Must order in quantities of two

Optional Indicator Mounts

- 41371 Mounting bracket for IQ 700 IS, stainless steel, 4" x 9.12"
- 43938 Mounting bracket for CW 80-I, stainless steel, 4" x 7.5"

DeckHand *Rough-n-Ready System*



Shown with optional ramp.



(SEE CHART ON BACK OF PAGE FOR PART NUMBERS)

Now available as a scale/indicator package, the DeckHand is more convenient and cost-effective than ever before!

The Rough-n-Ready System includes a mild steel DeckHand partnered with the IQ plus® 590-DC. This battery-powered indicator features a full numeric keypad, piece count mode, and a configurable standby mode that prolongs battery life. The scale is factory-wired and calibrated to reduce setup time to mere minutes. In fact, you can save time and money by having the entire package drop-shipped directly to the customer. In addition, the indicator and scale are shipped in the same carton to further reduce expenses.

Standard Features

DeckHand Rough-n-Ready System

- **Package includes:** Mild steel DeckHand Portable Scale and IQ plus 590-DC indicator
- Factory-wired and calibrated
- Treaded top plate
- Mild steel wheeled frame, base, and mast
- 500 lb, 1000 lb, 2000 lb capacity
- Large rubber wheels simplify movement on uneven floors
- One-person portability
- RL1260 aluminum load cells

IQ plus 590-DC indicator

See back of page for standard features

Options/Accessories

- 43376 Ramp assembly, 500/1000 lb, mild steel, 25" x 27"
- 43378 Ramp assembly, 2000 lb, mild steel, 25" x 27"
- 43978 Additional DeckHand operating manual

DECKHAND PORTABLE SCALE

END LOAD CAPACITY:

100% end loading

mV/V OUTPUT:

2 mV/V

CABLE LENGTH:

9' 10" (3 m)

HEIGHT:

Weighing platter: 4.5" H when in weigh mode

COLUMN HEIGHT:

59"

APPROVALS:

NTEP certified, CC# 98-004, Class III, 2500d;
Measurement Canada approved, AM-5218

WARRANTY:

1-year limited warranty

Please refer to indicator section for IQ plus 590-DC specifications

IQ PLUS 590-DC STANDARD FEATURES

- Full numeric keypad
- Keyboard entry of piece weight, tare weight, calibration, and sample size
- Display tare button
- Powered by 6 "C" cell alkaline batteries for complete portability (batteries not included)
- Revolution™ Scale Software supported
- Three 300-character print ticket formats
- Power for four 350Ω load cells or eight 700Ω load cells
- Supports 4- and 6-wire load cell connections
- EDP port for full, duplex RS-232 communications
- NEMA 4X/IP66-rated stainless steel enclosure
- Large 1" (24.5 mm), six-digit LCD display
- AC adapter for 115 or 230 VAC power
- Configurable standby mode to prolong battery life
- RATTLETRAP® three-stage digital filtering
- Configurable units multiplier
- Configurable analog-to-digital measurement rate
- Self-resetting thermal fuse
- 2-year limited warranty



Measurement
Canada
Approved

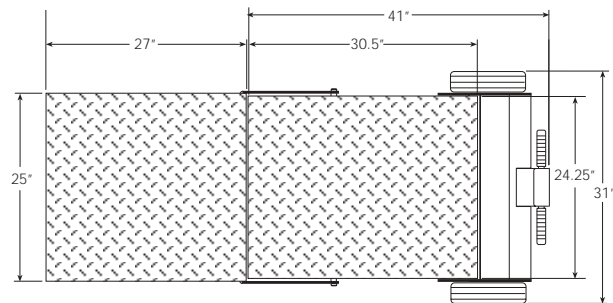
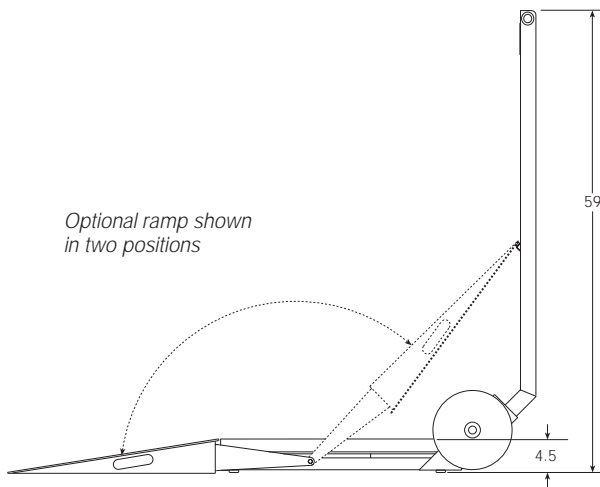

DECKHAND PORTABLE SCALE — SCALE ONLY

PART #	MODEL	OVERALL SIZE (W x L x H)	CAPACITY	EST. SHIP WT
Mild Steel				
41293	DH-500	31" x 41" x 4.5"	500 lb (226.8 kg)	336 lb (152 kg)
41294	DH-1000	31" x 41" x 4.5"	1000 lb (453.6 kg)	356 lb (161 kg)
41295	DH-2000	31" x 41" x 4.5"	2000 lb (907.2 kg)	373 lb (169 kg)
Stainless Steel				
41296	DH-500	31" x 41" x 4.5"	500 lb (226.8 kg)	336 lb (152 kg)
41297	DH-1000	31" x 41" x 4.5"	1000 lb (453.6 kg)	356 lb (161 kg)
41298	DH-2000	31" x 41" x 4.5"	2000 lb (907.2 kg)	373 lb (169 kg)

DECKHAND ROUGH-N-READY SYSTEM — SCALE AND INDICATOR PACKAGE

PART #	DECKHAND CAPACITY	OVERALL SIZE (W x L x H)	INDICATOR	EST. PACKAGE SHIP WEIGHT*
Mild Steel Only				
69525	500 lb x 0.2 lb	31" x 41" x 4.5"	IQ plus 590-DC, 115 VAC	343 lb (155 kg)
69526	1000 lb x 0.5 lb	31" x 41" x 4.5"	IQ plus 590-DC, 115 VAC	363 lb (164 kg)
69527	2000 lb x 1.0 lb	31" x 41" x 4.5"	IQ plus 590-DC, 115 VAC	380 lb (172 kg)
69528	500 lb x 0.2 lb	31" x 41" x 4.5"	IQ plus 590-DC, 230 VAC	343 lb (155 kg)
69529	1000 lb x 0.5 lb	31" x 41" x 4.5"	IQ plus 590-DC, 230 VAC	363 lb (164 kg)
69530	2000 lb x 1.0 lb	31" x 41" x 4.5"	IQ plus 590-DC, 230 VAC	380 lb (172 kg)

* Approximate weight for scale and indicator.