

CLS-420 Cargo Lift Scale



Approvals



Standard Features

- NTEP-Certified, 5,000 lb
- Two 5,000 lb stainless steel load cells
- Compatible with Class II forklift, 16" cleat style carriage
- Mechanical overload stops promote scale longevity and accuracy
- Panoramic 6" x 20-3/4" view port
- Reinforced cover plate protects load cells and junction box from debris
- Welded centering pin ensures proper alignment and prevents scale from lateral movement
- Two-channel iQUBE®
- Cal-Match™ algorithm automatically trims and calibrates scale

Wired Version

- Coiled interface cable from scale to indicator

Wireless Version

- ZigBee™ connection from scale to indicator
- Two lithium-ion Smart batteries included. Scale operates using one battery for 24 continuous hours and requires only eight hours to fully charge.
- External battery charger

420 Indicator

- Stainless steel enclosure
- Two-piece mounting assembly with vibration isolators
- Six digit, 0.8" red LED display
- Full numeric keypad
- RS-232 port (time and date, weight)
- Full front-panel digital calibration
- On/Off on-touch key for forklift battery conservation
- Setpoint key to view battery hours remaining (wireless version)

Specifications

SCALE CAPACITY:

5,000 lb

SCALE OVERLOAD:

200%

ULTIMATE OVERLOAD:

5:1 capacity

SCALE POWER:

Wired Version: supplied by indicator through coiled interface cable

Wireless Version: supplied by one lithium-ion Smart battery (SMBus revision 1.1 fully compliant)

SCALE MATERIAL/FINISH:

Painted Mild Steel

SCALE WARRANTY:

1-year limited warranty

SCALE APPROVAL:

NTEP-certified per H-44 at 1,000 divisions, Class III, COC # 06-074

420 DISPLAY:

0.8" (20 mm), 6-digit Super Red Light Emitting Diode (LED) display, 7-segment, digits

420 POWER - DC:

Line voltages: 9.3-36 VDC DC input
Power consumption: 2.0 A Max

420 RATING/MATERIAL:

Enclosure: NEMA 4X/IP66, heavy gauge stainless steel

420 STATUS ANNUNCIATORS:

Designators for: center of zero, stand still, gross, net, lb, kg, count, tare

420 OPERATING TEMPERATURE

Legal: 14°F to 104°F (-10°C to 40°C)
Industrial: 14°F to 122°F (-10°C to 50°C)

420 WARRANTY:

2-year limited warranty

420 APPROVALS:

NTEP-certified per H-44 at 10,000 Divisions, Class III/IIIL, CC# 04-076

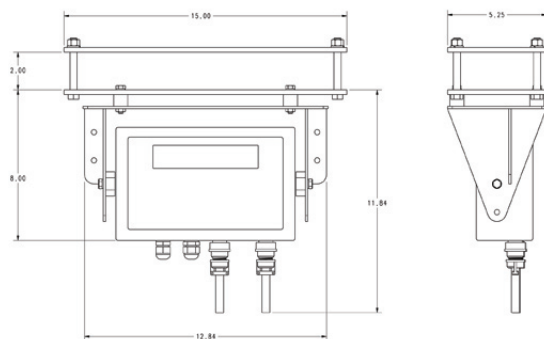

CLS-420

PART #	MODEL	WEIGHT	PRICE
CLS Forklift Scale			
96339	Scale PKG, 420 wired version	527 lb	\$6,550.00
96340	Scale PKG, 420 wireless version with 2 batteries and 2-bay charger	527 lb	7,815.00
Manuals			
96483	CLS-420 installation manual		20.00
96484	CLS-420 operator card		10.00
96315	Service & troubleshooting manual		35.00